

DIN 28115 Long Neck Welding Flange PN10 and PN25

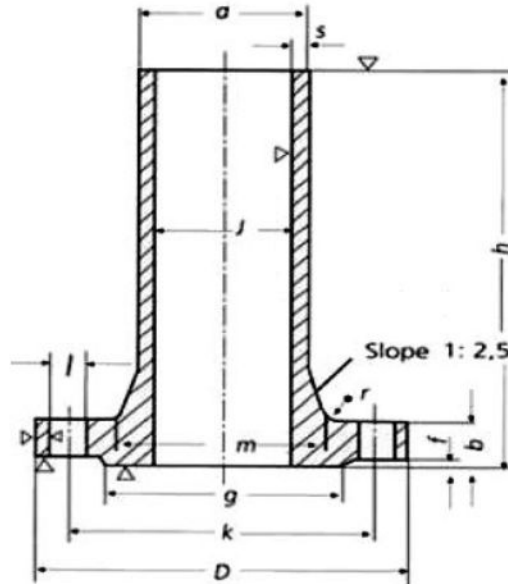

PN10																
DN	Service Pressure	a	s	D	j	b	h	m	r	g	f	k	No. of holes	l	Thread	KG
25	8 Kg/cm ² 200 °C	38	7	115	24	16	120	50	8	68	2	85	4	14	M12(1/2")	1,7
32		51	8	140	35	16	120	62	8	78	2	100	4	18	M16(5/8")	2,8
40		57	8	150	41	16	120	70	8	88	3	110	4	18	M16(5/8")	3,2
50		70	8	165	54	18	120	85	8	102	3	125	4	18	M16(5/8")	4,2
65		89	8	185	73	18	170	104	8	122	3	145	4	18	M16(5/8")	6,8
80		102	8	200	86	20	170	118	8	138	3	160	4	18	M16(5/8")	7,8
100		121	10	220	101	20	170	138	8	158	3	180	8	18	M16(5/8")	9,7
125		146	10	250	126	22	170	164	10	188	3	210	8	18	M16(5/8")	11,6
150		171	10	285	151	22	170	188	10	212	3	240	8	23	M20(3/4")	14
200		224	10	340	204	22	170	246	10	268	3	295	8	23	M20(3/4")	20,4

PN25																			
DN	Nominal Pressure Kg/cm ²			Service Pressure to 200°C	a	s	D	j	b	h	m	r	g	f	k	No. of holes	l	Thread	KG
25	16	25	40	32	38	7	115	24	18	120	50	8	68	2	85	4	14	M12(1/2")	1.9
32	16	25	40	32	51	8	140	35	18	120	62	8	78	2	100	4	18	M16(5/8")	3.0
40	16	25	40	32	57	8	150	41	18	120	70	8	88	3	110	4	18	M16(5/8")	3.2
50	16	25	40	32	70	8	165	54	20	120	85	8	102	3	125	4	18	M16(5/8")	4.5
65	16	.	.	13	89	8	185	73	22	170	104	8	122	3	145	4	18	M16(5/8")	7.5
	.	25	40	32	89	8	185	73	22	170	104	8	122	3	145	8	18	M16(5/8")	7.3
80	16	.	.	13	102	8	200	86	24	170	118	8	138	3	160	8	18	M16(5/8")	8.4
	.	25	40	32	102	8	200	86	24	170	118	8	138	3	160	8	18	M16(5/8")	8.4
100	16	.	.	13	121	10	220	101	24	170	138	8	158	3	180	8	18	M16(5/8")	9.8
125	16	.	.	13	146	10	250	126	26	170	164	10	188	3	210	8	18	M16(5/8")	12.6
150	16	.	.	13	171	10	285	151	28	170	188	10	212	3	240	8	23	M20(3/4")	15.8
200	16	.	.	13	224	10	340	204	34	170	246	10	268	3	295	12	23	M20(3/4")	24.2

Dimensions in millimeter (mm).