

Manual Sealed Knife Gate Valve

Feature

- Connection Rating:
JIS 5K JIS 10K JIS 7.5K
- ANSI 150#
- DIN PN10 PN16
- MSS-SP81 Test Standard:
Body Test: 11kg/cm² (Water)
- Seat Test: 2.8kg/cm² (Water)
- Leakage: 4 cc/ per in. min.

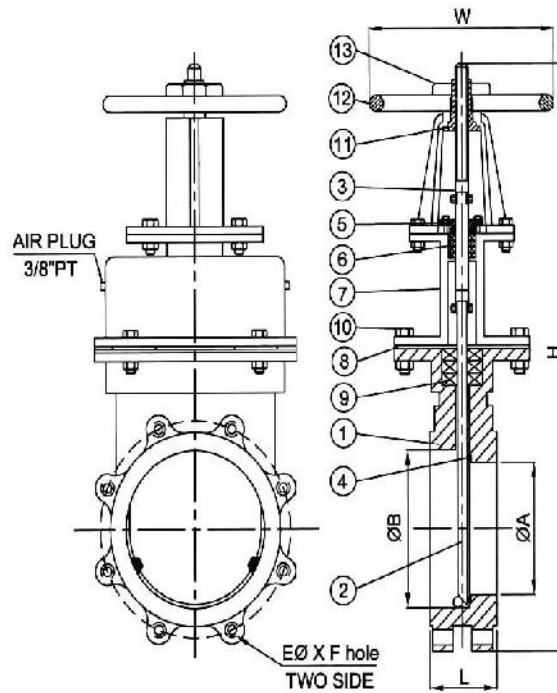

Temperature

MATERIAL	TEM. RANGE
ASBESTOS + PTFE	-50°C ~ 550°C
SILICON	-20°C ~ 150°C
VITON	-20°C ~ 250°C
TEFLON	-30°C ~ 150°C
NON ASBESTOS	-50°C ~ 550°C

Material Option

	BODY	PLATE	SEAT	GLAND PACKING
MATERIAL	FC WCB SCS13 SCS14 SCS16	SUS304 SUS316 SUS304L SUS316L	TEFLON METAL VITON EPDM	NON-ASB+PTFE ASB ASB+PTFE TEFLON NON ASBESTOS

Dimension

SIZE	L	ØA	ØB	W	H
2"	48	42	64	190	570
2-1/2"	51	57	80	190	585
3"	51	72	95	190	650
4"	51	98	122	220	720
5"	57	123	146	290	870
6"	57	150	175	290	950
8"	70	195	225	350	1200
10"	70	250	275	350	1370
12"	76	300	325	406	1560
14"	76	350	375	406	1700
16"	89	400	430	500	2000
18"	89	435	475	500	2200
20"	114	480	515	500	2700

Material List

NO.	PART NAME	MATERIAL
1	BODY	CF8/CF8M
2	SHUT PLATE	CF8/CF8M
3	STEM	SUS304/410
4	SEAT	PTFE/METAL
5	GLAND	CF8
6	GLAND PACKING	PTFE
7	BONNET	CF8
8	PLATE	BC6, AL ALLOY
9	PACKING	ASB+PTFE
10	BOLT	SUS304
11	SLEEVE	FCD
12	HAND WHEEL	CAST IRON
13	NUT	CAST IRON