

Pneumatic Slide Knife Gate Valve

Feature

Connection Rating:
 JIS 5K JIS 10K JIS 7.5K
 ANSI 150#
 DIN PN10 PN16
 MSS-SP81 Test Standard:
 Body Test: 11kg/cm² (Water)
 Seat Test: 2.8kg/cm² (Water)
 Leakage: 40 cc/per in. min.

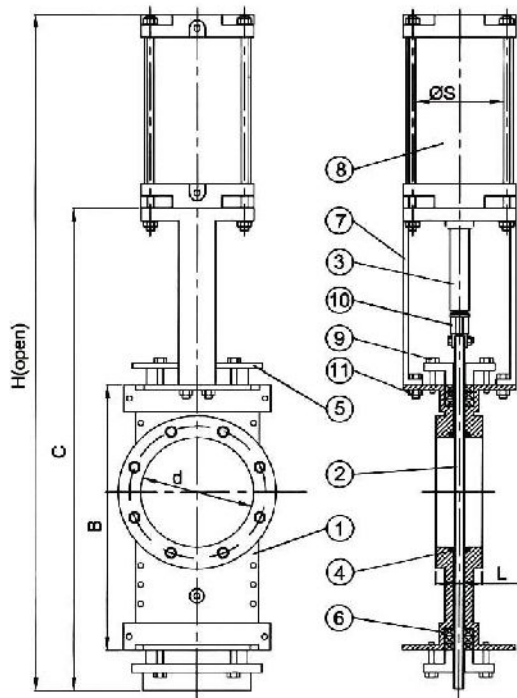

Temperature

MATERIAL	TEM. RANGE
ASBESTOS + PTFE	-50°C ~ 550°C
SILICON	-20°C ~ 150°C
VITON	-20°C ~ 250°C
TEFLON	-30°C ~ 150°C
NON ASBESTOS	-50°C ~ 550°C

Material Option

	BODY	PLATE	SEAT	GLAND PACKING
MATERIAL	FC WCB SCS13 SCS14 SCS16	SUS304 SUS316 SUS304L SUS316L	MAT'L	NON-ASB+PTFE ASB ASB+PTFE NON ASBESTOS

Dimension

SIZE	d	L	B	C	H	ØS
4"	95	50	360	590	980	80
5"	122	50	426	640	1170	125
6"	140	60	458	720	1300	125
8"	188	60	450	870	1630	150
10"	240	70	668	1020	1920	180
12"	293	70	800	1120	2160	200
14"	320	70	930	1290	2500	250
16"	360	90	990	1580	2710	250
18"	430	90	1180	1730	3320	250
20"	490	110	1340	2000	3560	300
24"	545	110	1560	2350	3755	300

Material List

NO.	PART NAME	MATERIAL
1	BODY	FC/FCD
2	PLATE	SUS304/316
3	STEM	SS41+HCr
4	SEAT	TEFLON. METAL
5	GLAND	CAST IRON
6	GLAND PACKING	ASB NON-ASB
7	YOKE	FC FCD
8	ACTUATOR	AL ALLOYS FC
9	BOLT NUT	MILD STEEL
10	CONNECTORVER	SUS304
11	NUT	MILD STEEL