

### Manual Square Knife Gate Valve

**Feature**

- Connection Rating:  
JIS 5K JIS 10K JIS 7.5K
- ANSI 150#
- DIN PN10 PN16
- MSS-SP81 Test Standard:  
Body Test: 11kg/cm<sup>2</sup> (Water)
- Seat Test: 2.8kg/cm<sup>2</sup> (Water)
- Leakage: 4 cc/ per in. min.

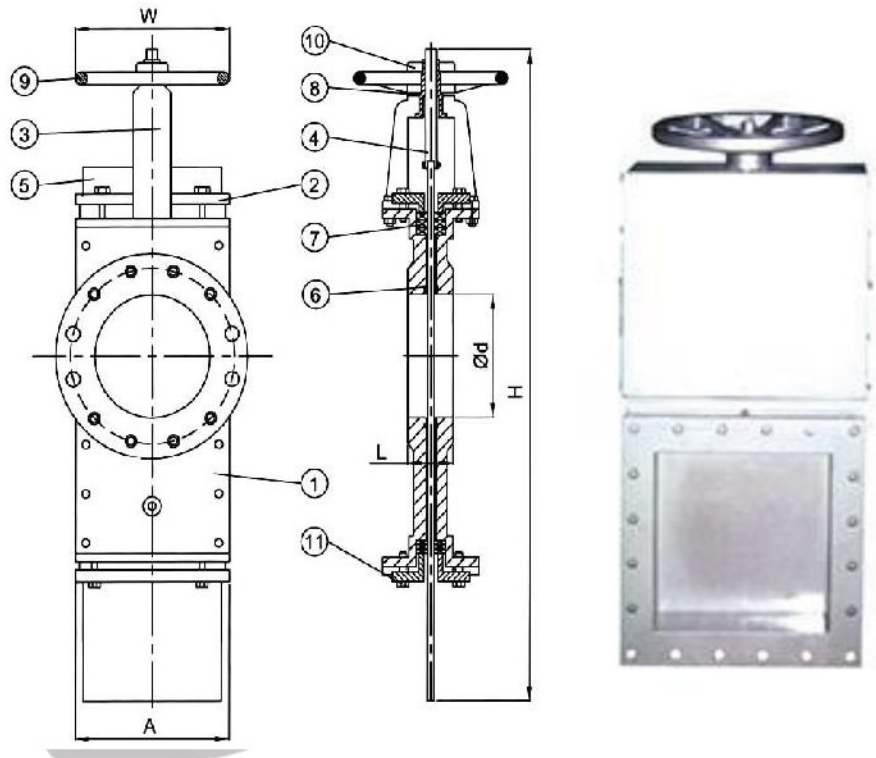

**Temperature**

MATERIAL	TEM. RANGE
ASBESTOS + PTFE	-50°C ~ 550°C
SILICON	-20°C ~ 150°C
VITON	-20°C ~ 250°C
TEFLON	-30°C ~ 150°C
NON ASBESTOS	-50°C ~ 550°C

**Material Option**

MATERIAL	BODY	PLATE	SEAT	GLAND PACKING
	CF8	SUS304	TEFLON	NON-ASB+PTFE
	CF8M	SUS316	METAL	ASB
	CF3M	SUS304L	VITON	ASB+PTFE
	FC	SUS316L	EPDM	TEFLON
	FCD			NON ASBESTOS

**Dimension**

SIZE	L	A	Ød	W	H
4"	50	170	95	220	760
5"	50	200	122	290	870
6"	60	225	140	290	980
8"	60	275	188	385	1220
10"	70	330	240	385	1410
12"	70	390	293	400	1635
14"	70	430	320	400	1930
16"	90	495	360	500	2200
18"	90	600	430	500	2450
20"	110	620	490	500	2575
24"	110	650	545	500	2750

**Material List**

NO.	PART NAME	MATERIAL
1	BODY	FC/SUS304
2	GRAND	FC/SUS304
3	YOKE	FC/FCD
4	STEM	SUS410/304
5	PLATE	SUS304/316
6	SEAT	PTFE
7	PACKING	ASB NON-ASB
8	YOKE SLEEVE	BRONZE
9	HAND WHEEL	FC
10	NUT	FC
11	BOLT	MILD STEEL