

Pneumatic Knife Gate Valve With Handwheel

Feature

- Connection Rating:
JIS 5K JIS 10K JIS 7.5K
- ANSI 150#
- DIN PN10 PN16
- MSS-SP81 Test Standard:
Body Test: 11kg/cm² (Water)
- Seat Test: 2.8kg/cm² (Water)
- Leakage: 4 cc/ per in. min.

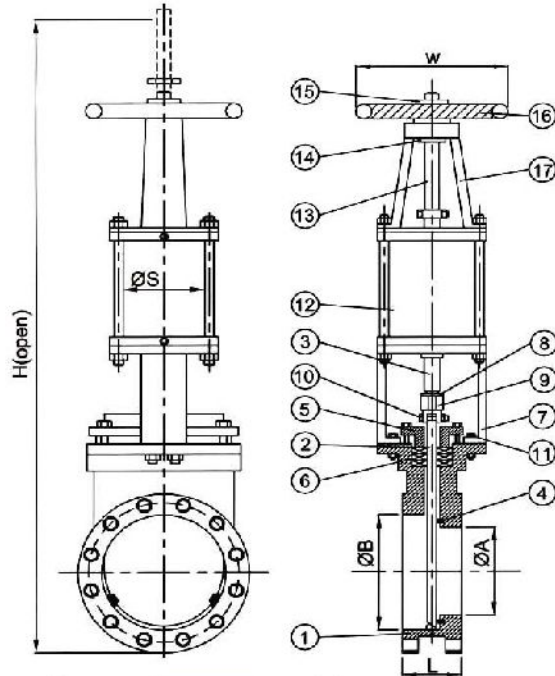

Temperature

MATERIAL	TEM. RANGE
ASBESTOS + PTFE	-50°C ~ 550°C
SILICON	-20°C ~ 150°C
VITON	-20°C ~ 250°C
TEFLON	-30°C ~ 150°C
NON ASBESTOS	-50°C ~ 550°C

Material Option

	BODY	PLATE	SEAT	GLAND PACKING
MATERIAL	FC	SUS304	TEFLON	NON-ASB+PTFE
	WCB	SUS316	METAL	ASB
	SCS13	SUS304L	VITON	ASB+PTFE
	SCS14	SUS316L	EPDM	TEFLON
	SCS16			NON ASBESTOS

Dimension

SIZE	L	ØA	ØB	W	H	ØS
2"	48	42	64	190	755	63
2-1/2"	51	57	80	190	855	63
3"	51	72	95	190	975	80
4"	51	95	120	220	1085	80
5"	57	125	148	290	1310	125
6"	57	150	175	290	1445	125
8"	70	195	222	350	1755	150
10"	70	250	275	350	2095	180
12"	76	300	325	400	2365	200
14"	76	350	375	400	2710	250
16"	89	400	430	400	2950	250
18"	89	435	475	500	3375	250
20"	114	480	515	500	3685	300
24"	114	580	620	500	4235	300

Material List

NO.	PART NAME	MATERIAL
1	BODY	CF8,CF8M
2	SHUT PLATE	SUS304
3	STEM	SS41+HCr
4	SEAT	TEFLON
5	GLAND	CF8
6	GLAND PACKING	ASB NON-ASB
7	YOKE	DUCTILE IRON
8	POINTER	SUS304
9	NUT	SUS304
10	CONNECTOR	SUS304
11	BOLT AND NUT	SUS304
12	ACTUATOR	AL ALLOY. FC
13	STEM	S.S.410
14	YOKE SLEEVE	CAST BRONZE. FCD
15	NUT	CAST IRON
16	HAND WHEEL	CAST IRON
17	YOKE	CAST IRON