

Electric Operated Knife Gate Valve

Feature

Connection Rating:

JIS 5K JIS 10K JIS 7.5K

ANSI 150LB

DIN PN10 PN16

MSS-SP81 Test Standard:

Body Test: 11kg/cm² (Water)

Seat Test: 2.8kg/cm² (Water)

Leakage: 4 cc/ per in. min.

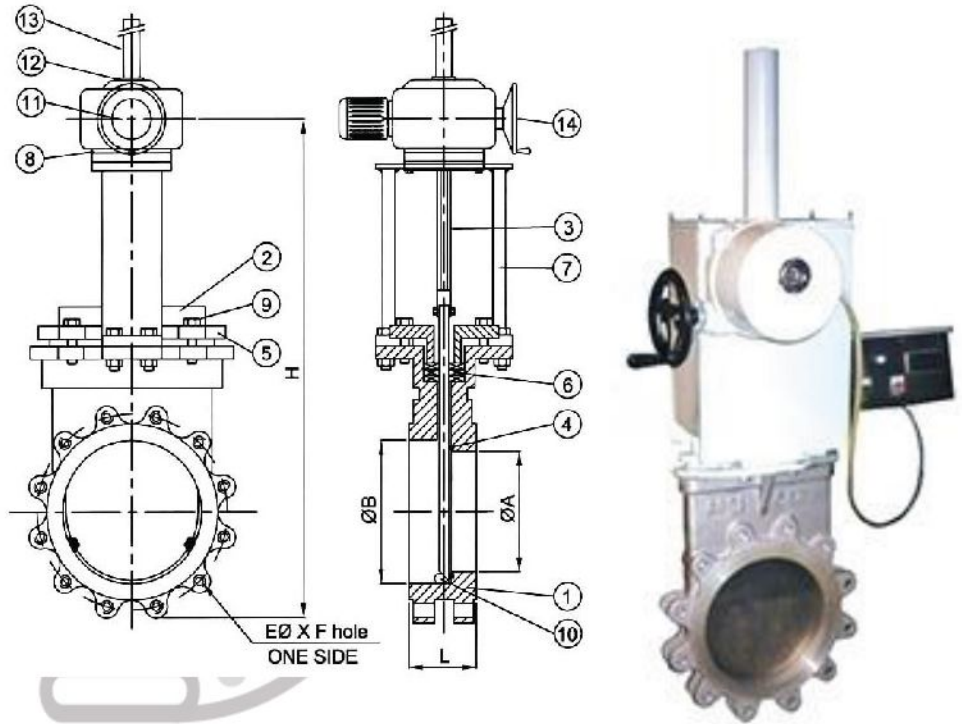

Temperature

| MATERIAL | TEM. RANGE |
|-----------------|---------------|
| ASBESTOS + PTFE | -50°C ~ 550°C |
| SILICON | -20°C ~ 150°C |
| VITON | -20°C ~ 250°C |
| TEFLON | -30°C ~ 150°C |
| NON ASBESTOS | -50°C ~ 550°C |

Material Option

| | BODY | PLATE | SEAT | GLAND PACKING |
|----------|------|---------|--------|------------------------|
| MATERIAL | CF8 | SUS304 | TEFLON | NON-ASB+PTFE |
| | CF8M | SUS316 | METAL | ASB |
| | CF3M | SUS304L | VITON | ASB+PTFE |
| | FC | SUS316L | EPDM | TEFLON NON ASBESTOS |

Dimension

| SIZE | L | ØA | ØB | H |
|--------|-----|-----|-----|------|
| 2" | 48 | 42 | 64 | 420 |
| 2-1/2" | 51 | 57 | 80 | 430 |
| 3" | 51 | 72 | 95 | 430 |
| 4" | 51 | 95 | 120 | 520 |
| 5" | 57 | 125 | 148 | 640 |
| 6" | 57 | 150 | 175 | 680 |
| 8" | 70 | 195 | 222 | 780 |
| 10" | 70 | 250 | 275 | 950 |
| 12" | 76 | 300 | 325 | 1150 |
| 14" | 76 | 350 | 375 | 1230 |
| 16" | 89 | 400 | 430 | 1420 |
| 18" | 89 | 435 | 475 | 1600 |
| 20" | 114 | 480 | 515 | 1700 |
| 24" | 114 | 580 | 620 | 1970 |

Material List

| NO. | PART NAME | MATERIAL |
|-----|---------------|---------------------|
| 1 | BODY | CF8.CF8M.CF3M.FC |
| 2 | PLATE | SUS304.316.316L |
| 3 | STEM | SUS410.304.316.316L |
| 4 | SEAT | TEFLON.EPDM |
| 5 | GLAND | SUS304 |
| 6 | GLAND PACKING | ASB ; TEFLON |
| 7 | YOKE | SS400 |
| 8 | YOKE SLEEVE | DUCTILE IRON |
| 9 | BOLT NUT | SUS304 |
| 10 | PAWLS | SUS304.316.317 |
| 11 | GEAR | SS41 |
| 12 | MOTOR | AL ALLOY |
| 13 | TUBE | CARBON STEEL |
| 14 | HAND WHEEL | CAST IRON |