

Pneumatic Stainless Steel Knife Gate Valve

Feature

- Connection Rating:
JIS 5K JIS 10K JIS 7.5K
- ANSI 150#
- DIN PN10 PN16
- MSS-SP81 Test Standard:
Body Test: 11kg/cm² (Water)
- Seat Test: 2.8kg/cm² (Water)
- Leakage: 4 cc/ per in. min.

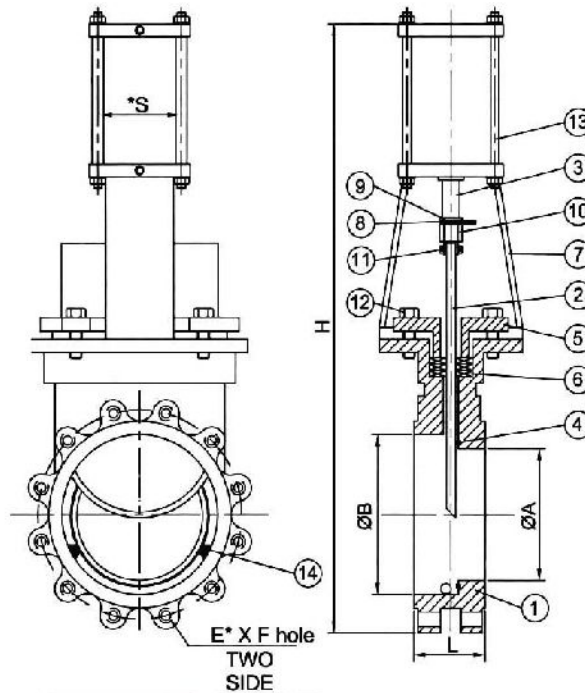

Temperature

MATERIAL	TEM. RANGE
ASBESTOS + PTFE	-50°C ~ 550°C
SILICON	-20°C ~ 150°C
VITON	-20°C ~ 250°C
TEFLON	-30°C ~ 150°C
NON ASBESTOS	-50°C ~ 550°C

Material Option

	BODY	PLATE	SEAT	GLAND PACKING
MATERIAL	CF8	SUS304	TEFLON	NON-ASB+PTFE
	CF8M	SUS316	METAL	ASB
	CF3M	SUS304L	VITON	ASB+PTFE
		SUS316L	EPDM	TEFLON
				NON ASBESTOS

Dimension

SIZE	L	ØA	ØB	ØS	H
2"	48	42	64	63	520
2-1/2"	51	57	80	63	570
3"	51	72	95	80	680
4"	51	95	120	80	755
5"	57	125	148	125	900
6"	57	150	175	125	960
8"	70	195	222	150	1160
10"	70	250	275	180	1440
12"	76	300	325	200	1605
14"	76	350	375	250	1860
16"	89	400	430	250	2070
18"	89	435	475	250	2200
20"	114	480	515	300	2400
24"	114	580	620	300	2750

Material List

NO.	PART NAME	MATERIAL
1	BODY	CF8.CF8M.CF3M
2	PLATE	SUS304.316.316L
3	STEM	SS41+HCr
4	SEAT	TEFLON
5	GLAND	SUS304
6	GLAND PACKING	ASB NON-ASB
7	YOKE	DUCTILE IRON
8	POINTER	SUS304
9	NUT	SUS304
10	NUT	SUS304
11	CONNECTOR	SUS304
12	BOLT AND NUT	SUS304
13	ACTUATOR	AL ALLOY. FC
14	GUIDE	SUS304