

Butt Weld 90° Branch Outlet

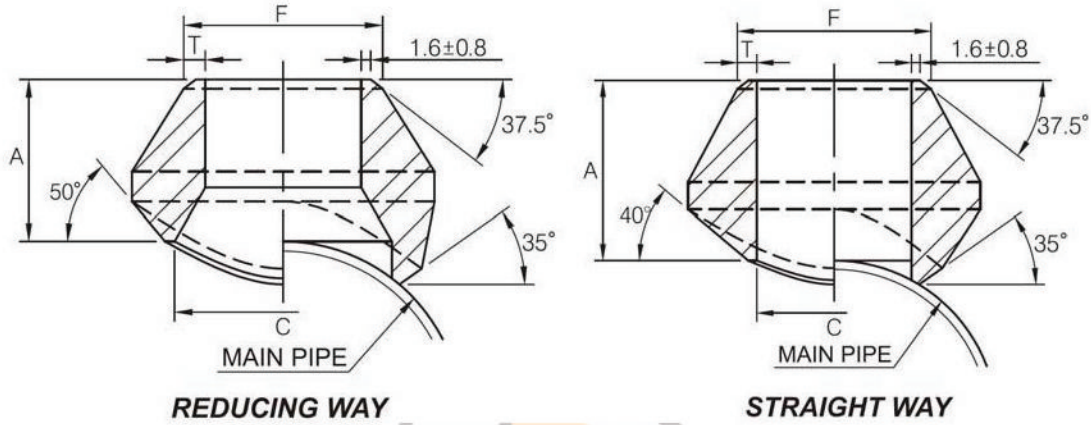

Standard Weight and Extra Strong

Outlet Pipe	Reducing Way					
	A		C	F	T	
	Standard	Extra Strong			Standard	Extra Strong
1/8"	15.7	15.7	13.7	10.3	1.73	2.41
1/4"	15.7	15.7	13.7	13.7	2.24	3.02
3/8"	19.1	19.1	17.1	17.1	2.31	3.20
1/2"	19.1	19.1	21.3	21.3	2.77	3.73
3/4"	22.4	22.4	26.7	26.7	2.87	3.91
1"	26.9	26.9	33.4	33.4	3.38	4.55
1-1/4"	31.8	31.8	42.2	42.2	3.56	4.85
1-1/2"	33.3	33.3	48.3	48.3	3.68	5.08
2"	38.1	38.1	60.3	60.3	3.91	5.54
2-1/2"	41.1	41.1	73.0	73.0	5.16	7.01
3"	44.4	44.4	88.9	88.9	5.49	7.62
3-1/2"	47.8	47.8	101.6	101.6	5.74	8.56
4"	50.8	50.8	114.3	114.3	6.02	8.56
5"	57.2	57.2	141.3	141.3	6.55	9.53
6"	60.4	77.7	168.3	168.3	7.11	10.97
8"	69.8	98.6	219.3	219.3	8.11	12.70
10"	77.7	93.7	273.1	273.1	9.27	12.70
12"	85.9	103.1	323.9	323.9	9.53	12.70
14"	88.9	100.1	355.6	355.6	9.53	12.70
16"	93.7	106.2	406.4	406.4	9.53	12.70
18"	96.8	111.2	457.2	457.2	9.53	12.70
20"	101.6	119.1	508.0	508.0	9.53	12.70
24"	115.8	139.7	609.6	609.6	9.53	12.70

Outlet Pipe	Straight Way				
	A	C	F	T	
				Standard	Extra Strong
1/8"	-	-	-	-	-
1/4"	15.7	11.5	13.7	2.24	3.02
3/8"	19.1	14.5	17.1	2.31	3.20
1/2"	19.1	16.5	21.3	2.77	3.73
3/4"	22.4	21.5	26.7	2.87	3.91
1"	26.9	27.2	33.4	3.38	4.55
1-1/4"	31.8	36.0	42.2	3.56	4.85
1-1/2"	33.3	42.0	48.3	3.68	5.08
2"	38.1	53.0	60.3	3.91	5.54
2-1/2"	41.1	65.0	73.0	5.16	7.01
3"	44.4	80.0	88.9	5.49	7.62
3-1/2"	-	-	-	-	-
4"	50.8	104.0	114.3	6.02	8.56