

Couplet Socket Weld

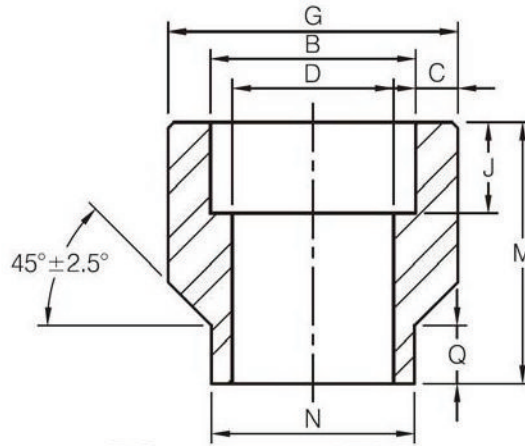

DN	Nom. Pipe Size	B	C ⁽¹⁾				D		J (Min)	N	Q	M	G	
			3M		6M		3M	6M					3M	6M
			Avg	Min	Avg	Min								
8	1/4"	14.2	3.78	3.30	4.60	4.01	9.3	6.4	9.5	17.5	9.5	30.2	23.8	25.4
10	3/8"	17.6	4.01	3.50	5.03	4.37	12.6	9.2	9.5	20.7	9.5	30.2	27.0	31.8
15	1/2"	21.8	4.67	4.09	5.97	5.18	15.8	11.8	9.5	23.8	9.5	33.4	33.4	38.1
20	3/4"	27.2	4.90	4.27	6.96	6.04	21.0	15.6	12.5	27.0	9.5	34.9	38.1	44.5
25	1"	33.9	5.69	4.98	7.92	6.93	26.7	20.7	12.5	33.4	9.5	42.9	46.1	57.2
32	1-1/4"	42.7	6.07	5.28	7.92	6.93	35.1	29.5	12.5	42.9	9.5	47.6	55.6	63.5
40	1-1/2"	48.8	6.35	5.54	8.92	7.80	40.9	34.0	12.5	49.2	9.5	50.8	63.5	76.2
50	2"	61.2	6.93	6.04	10.92	9.50	52.5	42.9	16.0	61.9	9.5	57.2	79.4	92.1
65	2-1/2"	73.9	8.76	7.67	-	-	62.7	-	16.0	73.0	9.5	63.5	92.1	-
80	3"	89.8	9.52	8.30	-	-	78.0	-	16.0	88.9	9.5	69.9	111.1	-
100	4"	115.2	10.69	9.35	-	-	102.3	-	19.0	114.3	9.5	76.2	141.3	-

- (1) Average of socket wall thickness around periphery shall be no less than listed values. The minimum values are permitted in localized areas.
- (2) 3M and 6M denote 3000Lb and 6000Lb.
- (3) Dimensions in accordance with ASME B16.11-2011.