

### Cast Stainless Steel Check Valve Flanged 20K/ 300LB

**Feature**

- Shell Wall Thickness: ANSI B16.34
- Face to Face ANSI B16.10 / JISB2002
- End Flanges ANSI B16.5 / JISB2210
- Bolted cover
- Swing type
- For horizontal lines
- Renewable seat ring
- Flanged ends
- Buttwelding ends

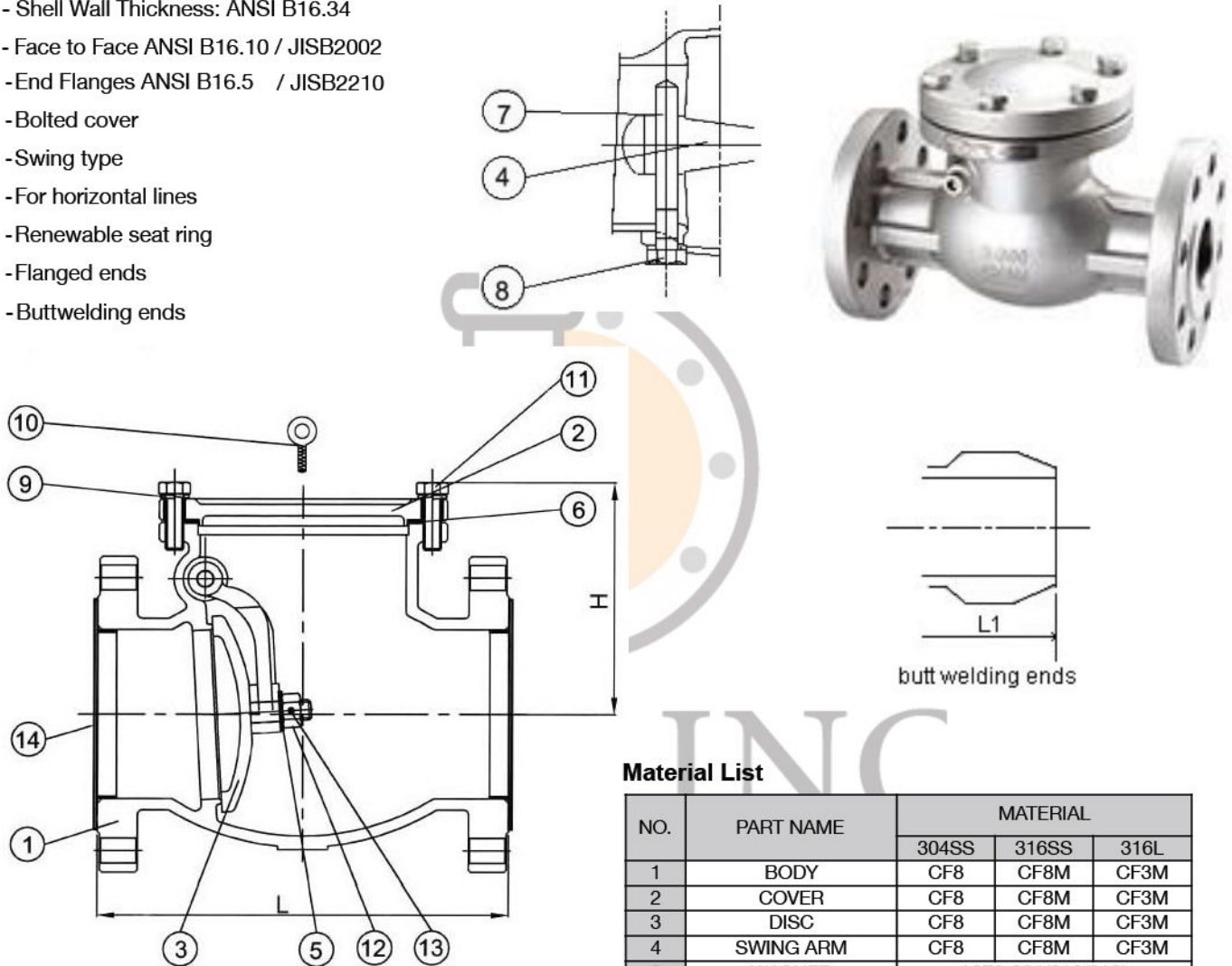

**Test Pressure To API 598**

	ANSI 300LB	JIS 20K
Shell Test (Water)	1125 PSI (77 kg/cm <sup>2</sup> )	20 kg/cm <sup>2</sup>
Seat Test (Water)	814 PSI (56 kg/cm <sup>2</sup> )	30 kg/cm <sup>2</sup>
Seat Test (Air)	80PSI (6 kg/cm <sup>2</sup> )	6 kg/cm <sup>2</sup>

**Material List**

NO.	PART NAME	MATERIAL		
		304SS	316SS	316L
1	BODY	CF8	CF8M	CF3M
2	COVER	CF8	CF8M	CF3M
3	DISC	CF8	CF8M	CF3M
4	SWING ARM	CF8	CF8M	CF3M
5	WASHER	A276-304/316/316L		
6	GASKET	V#1500/GRAPHITE/PTFE		
7	HINGE PIN	A276-304/316/316L		
8	PLUG	A276-304/316/316L		
9	SPRING WASHER	A276-304		
10	EYE BOLT	A36+ZN		
11	COVER BOLT	A193-B8		
12	NUT	A194-8/A194-8M		
13	PIN	A276-304/316/316L		
14	COVER	PE		

**Dimension**

SIZE	IN	1/2"	3/4"	1"	1-1/2"	2"	2-1/2"	3"	4"	5"	6"	8"	10"	12"
	MM	15	20	25	40	50	65	80	100	125	150	200	250	300
L		152	178	216	241	267	292	318	356	400	444	533	622	711
H		80	90	100	116	129	143	164	177	271	231	291	319	360