

Cast Stainless & Steel Check Valve Flanged 10K/150LB

Feature

- Shell Wall Thickness: ANSI B16.34
- Face to Face ANSI B16.10 / JISB2002
- End Flanges ANSI B16.5 / JISB2210
- Bolted cover
- Swing type
- For horizontal lines
- Renewable seat ring
- Flanged ends
- Butt welding ends

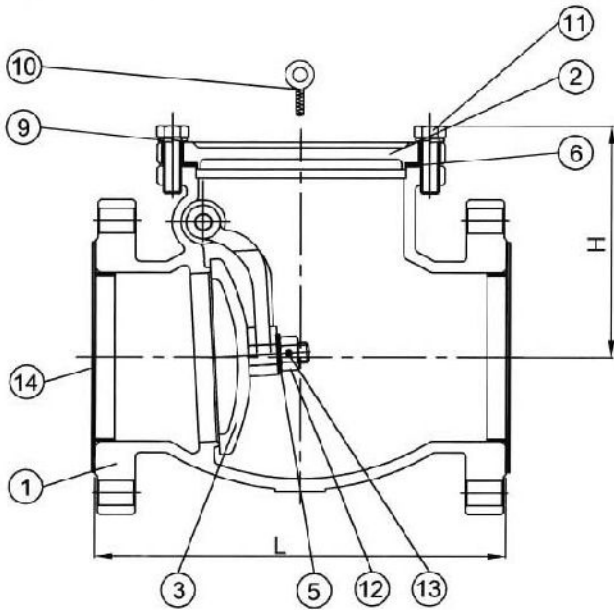
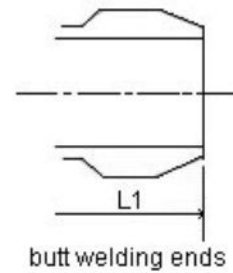
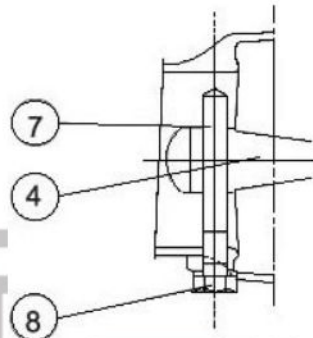

Material List

NO.	PART NAME	MATERIAL			
		304SS	316SS	316L	CS
1	BODY	CF8	CF8M	CF3M	WCB
2	COVER	CF8	CF8M	CF3M	WCB
3	DISC	CF8	CF8M	CF3M	WCB
4	SWING ARM	CF8	CF8M	CF3M	WCB
5	WASHER	A276-304/316/316L			
6	GASKET	V#1500/GRAPHITE/PTFE			
7	HINGE PIN	A276-304/316/316L			
8	PLUG	A276-304/316/316L			
9	SPRING WASHER	A276-304			
10	EYE BOLT	A36+ZN			
11	COVER BOLT	A193-B8			
12	NUT	A194-8/A194-8M			
13	PIN	A276-304/316/316L			
14	COVER	PE			

Test Pressure To API 598

	ANSI 150LB	JIS 10K
Shell Test (Water)	450 PSI (32 kg/cm ²)	20 kg/cm ²
Seat Test (Water)	314 PSI (22 kg/cm ²)	15 kg/cm ²
Seat Test (Air)	80PSI (6 kg/cm ²)	6 kg/cm ²

Dimension

SIZE	IN	1/2"	3/4"	1"	1-1/2"	2"	2-1/2"	3"	4"	5"	6"	8"	10"	12"	14"	16"	18"	20"	24"
	MM	15	20	25	40	50	65	80	100	125	150	200	250	300	350	400	450	500	600
L		108	117	127	165	203	216	241	292	330	356	495	622	699	787	864	978	978	1295
H		57	58	68	80	102	120	125	168	178	200	235	350	380	430	450	650	650	900