

**Two-way Ball Valve With Heating Jacket Flanged 10K/150LB**

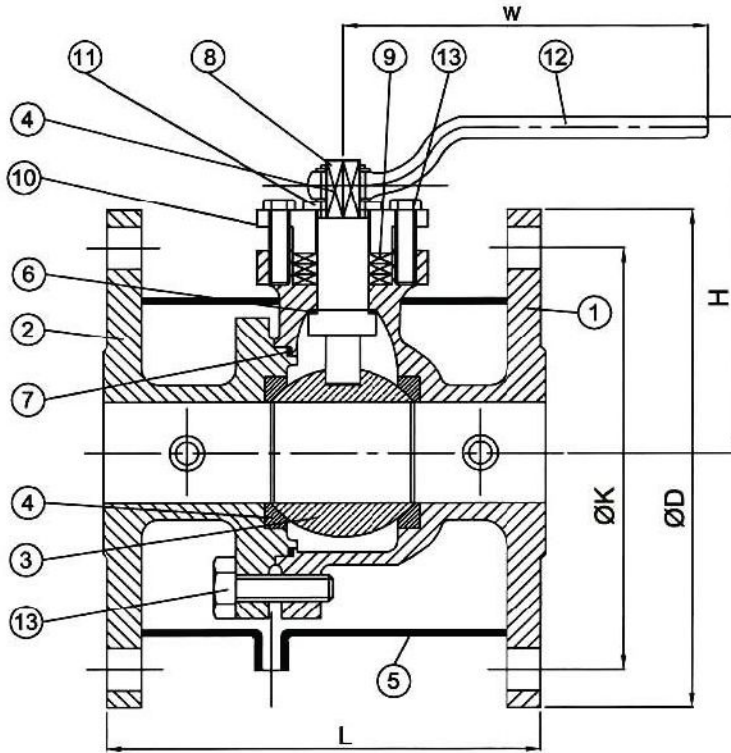

**Test Pressure To API 598**

	ANSI 150LB
Shell test (water)	450 PSI / 32 kg/cm <sup>2</sup>
Seat test (water)	315 PSI / 22 kg/cm <sup>2</sup>
Seat test (air)	80 PSI / 6kg cm <sup>2</sup>

**ANSI 150LB Dimension**

SIZE	IN	1/2	3/4	1	1-1/2	2	2-1/2	3	4	6
	MM	15	20	25	40	50	65	80	100	150
H		130	135	140	155	180	185	185	235	290
L		110	120	130	165	180	190	200	235	286
ØD		127	127	152	178	190	229	254	279	343
ØK		98.6	98.6	120.7	139.7	154.2	190.5	216	241.3	298.4

**JIS 10K Dimension**

SIZE	IN	1/2	3/4	1	1-1/2	2	2-1/2	3	4	6
	MM	15	20	25	40	50	65	80	100	150
H		130	135	140	155	180	185	185	235	290
L		110	120	130	165	180	190	200	235	270
ØD		140	140	155	175	185	210	250	280	330
ØK		105	105	120	140	150	175	210	240	290

**Material List**

NO.	PART NAME	MATERIAL
1	BODY	A351-CF8/ A351-CF8M
2	BONNET	A351-CF8/ A351-CF8M
3	BALL	A351-CF8/ A351-CF8M
4	SEAT	PTFE+33%C
5	SHELL OF JACKET	A240-304/ A240-316
6	THRUST WASHER	PTFE+33%C
7	GASKET	PTFE+33%C
8	STEM	A276-304
9	PACKING	GRAPHITE
10	GLAND	A351-CF8
11	STOPPER	A267-304
12	HANDLE	FCD-45
13	BOLT	SUS304