

45° Elbow Socket Weld

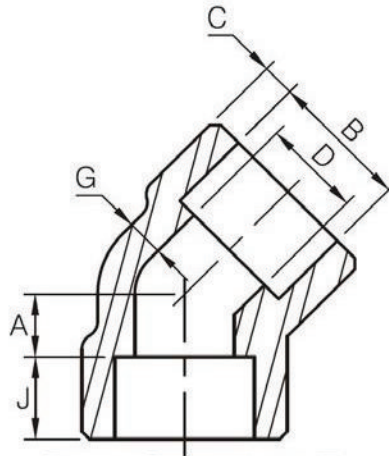

DN	Nom. Pipe Size	A			B	D			C ⁽¹⁾						G (Min)			J (Min)
		3M	6M	9M		3M	6M	9M	3M		6M		9M		3M	6M	9M	
									Avg	Min	Avg	Min	Avg	Min				
6	1/8"	8.0	8.0	-	10.8	6.9	4.0	-	3.18	3.18	3.96	3.43	-	-	2.41	3.15	-	9.5
8	1/4"	8.0	8.0	-	14.2	9.3	6.4	-	3.78	3.30	4.60	4.01	-	-	3.02	3.68	-	9.5
10	3/8"	8.0	11.0	-	17.6	12.6	9.2	-	4.01	3.50	5.03	4.37	-	-	3.20	4.01	-	9.5
15	1/2"	11.0	12.5	15.5	21.8	15.8	11.8	6.4	4.67	4.09	5.97	5.18	9.35	8.18	3.73	4.78	7.47	9.5
20	3/4"	13.0	14.0	19.0	27.2	21.0	15.6	11.1	4.90	4.27	6.96	6.04	9.78	8.56	3.91	5.56	7.82	12.5
25	1"	14.0	17.5	20.5	33.9	26.7	20.7	15.2	5.69	4.98	7.92	6.93	11.38	9.96	4.55	6.35	9.09	12.5
32	1-1/4"	17.5	20.5	22.5	42.7	35.1	29.5	22.8	6.07	5.28	7.92	6.93	12.14	10.62	4.85	6.35	9.70	12.5
40	1-1/2"	20.5	25.5	25.5	48.8	40.9	34.0	28.0	6.35	5.54	8.92	7.80	12.70	11.12	5.08	7.14	10.15	12.5
50	2"	25.5	28.5	28.5	61.2	52.5	42.9	38.2	6.93	6.04	10.92	9.50	13.84	12.12	5.54	8.74	11.07	16.0
65	2-1/2"	28.5	-	-	73.9	62.7	-	-	8.76	7.67	-	-	-	-	7.01	-	-	16.0
80	3"	32.0	-	-	89.8	78.0	-	-	9.52	8.30	-	-	-	-	7.62	-	-	16.0
100	4"	41.0	-	-	115.2	102.3	-	-	10.69	9.35	-	-	-	-	8.56	-	-	19.0

- (1) Average of socket wall thickness around periphery shall be no less than listed values. The minimum values are permitted in localized areas.
- (2) 3M, 6M and 9M denote 3000Lb, 6000Lb and 9000Lb.
- (3) Dimensions in accordance with ASME B16.11-2011.