

3PC Ball Valve Flanged PN16, Full Port, Direct Mounting

Features

1. Face to face: DIN 3202 F4/F5
2. End flange: PN 16 DIN 2633
3. Design: ANSI 16.34
4. Investment casting
5. Blow-out proof stem
6. Pressure: PN16

Options

1. Carbon/ Stainless steel body construction
2. Locking device available if requested

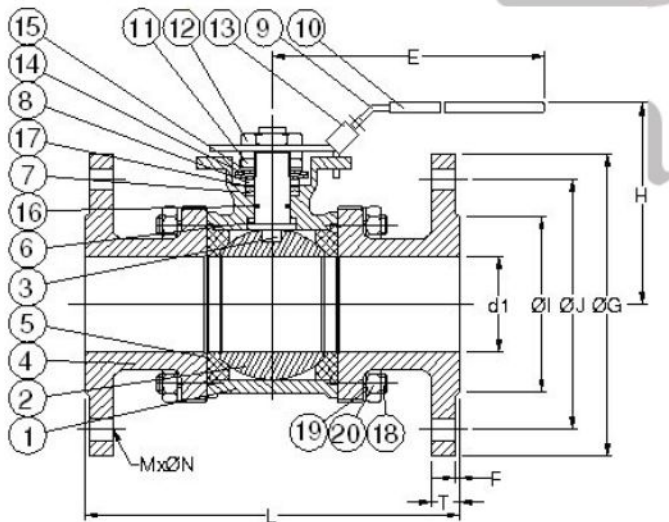
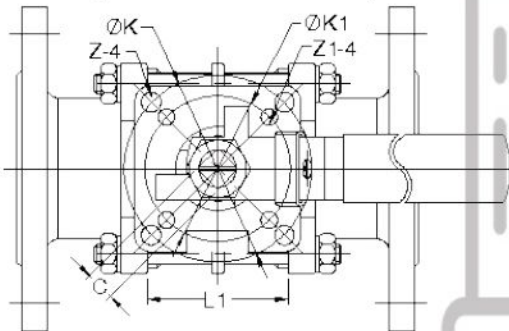

Material List

NO.	PART NAME	MATERIAL
1	BODY	1.4408/EN1503-1
2	BALL	CF8M/EN1503-2
3	STEM	SS316
4	END CAP	1.4408/EN1503-1
5	SEAT	RTFE
6	THRUST WASHER	RTFE
7	STEM PACKING	RTFE
8	GLAND BUSH	SS304
9	HANDLE	SS304
10	HANDLE COVER	PLASTIC
11	STEM NUT	SS304
12	HANDLE NUT	SS304
13	LOCKING PAD	SS304
14	BELLEVILLE WASHER	SS304-CSP
15	TAB WASHER	SS304
16	O-RING	VITON
17	PACKING FOLLOWER	PTFE+25%GF
18	BODY BOLT	SS304
19	BOLT WASHER	SS304
20	BOLT NUT	SS304

Dimension

SIZE	d1	L	E	H	C	ØG	ØJ	ØI	T	F	MxØN	ØK	ØK1	Z-4	Z1-4	L1	
DN15	1/2"	15.0	130.0	112.0	74.0	9.0	95.0	65.0	45.0	16.0	2.0	4xØ14	50.0	36.0	7.0	6.0	22.5
DN20	3/4"	20.0	150.0	112.0	81.0	9.0	105.0	75.0	58.0	18.0	2.0	4xØ14	50.0	36.0	7.0	6.0	27.5
DN25	1"	25.0	160.0	136.0	90.5	9.0	115.0	85.0	68.0	18.0	2.0	4xØ14	50.0	36.0	7.0	6.0	34.0
DN32	1-1/4"	32.0	180.0	185.0	98.7	9.0	140.0	100.0	78.0	18.0	2.0	4xØ18	50.0	36.0	7.0	6.0	42.5
DN40	1-1/2"	38.0	200.0	198.0	115.3	14.0	150.0	110.0	88.0	18.0	3.0	4xØ18	70.0	50.0	9.0	7.0	52.0
DN50	2"	50.0	230.0	198.0	124.0	14.0	165.0	125.0	102.0	20.0	3.0	4xØ18	70.0	50.0	9.0	7.0	63.5
DN65	2-1/2"	65.0	290.0	267.0	155.0	17.0	185.0	145.0	122.0	18.0	3.0	4xØ18	102.0	70.0	11.0	9.0	85.5
DN80	3"	80.0	310.0	267.0	208.5	17.0	200.0	160.0	138.0	20.0	3.0	8xØ18	102.0	70.0	11.0	9.0	102.0
DN100	4"	100.0	350.0	322.0	216.7	17.0	220.0	180.0	158.0	20.0	3.0	8xØ18	102.0	70.0	11.0	9.0	128.5