

2 Piece Ball Valve Flanged PN16/PN40, Full Port

Features

- 1.Face to face: DIN 3202 F4/F5
- 2.End Flange: DIN2633
- 3.Design: ANSI B16.34
- 4.Investment casting
- 5.Blow-out proof stem
- 6.Pressure: PN16/PN40

Options

1. Carbon/ Stainless steel body construction
2. Locking device available if requested

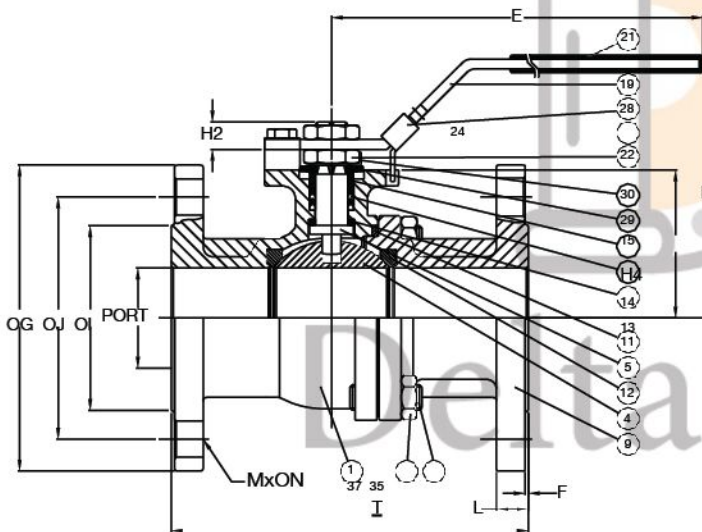
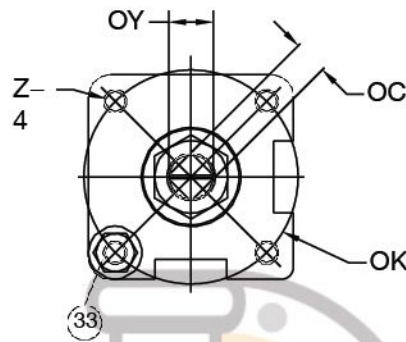

Materials List

NO.	PART NAME	MATERIAL	
1	BODY	1.4408/ EN1503-1	1.0619/ EN1503-1
4	BALL	SS316	SS304
5	STEM	SS316	SS304
9	END CAP	1.4408/ EN1503-1	1.0619/ EN1503-1
11	BODY SEAL	PTFE.	
12	SEAT	RTFE.	
13	THRUST WASHER	PTFE.	
14	STEM PACKING	PTFE.	
15	GLAND BUSH	SS304	
19	HANDLE	SS304	
21	HANDLE COVER	PLASTIC	
22	STEM NUT	SS304	
24	HANDLE NUT	SS304	
28	LOCKING PAD	SS304	
29	BELLEVILLE WASHER	SS301	
30	TAB WASHER	SS304	
33	STOP PIN	SS304	
35	BODY BOLT	ASTM A193 Gr.B8	ASTM A193 Gr.B7
37	BOLT NUT	ASTM A193 Gr.8	ASTM A193 Gr.2HM

PN16/PN40 Dimensions

Size	PORT	L	E	H	H2	H4	C	ØY	ØG	ØJ	ØI	T	F	M	ØN	ØK	Z	
DN15	1/2"	15.0	115.0	132.0	80.0	8.5	38.5	9.0	11.2	95.0	65.0	45.0	16.0	2.0	4	14.0	42.0	M5*0.8P
DN20	3/4"	20.0	120.0	132.0	84.5	8.5	42.5	9.0	11.2	105.0	75.0	58.0	18.0	2.0	4	14.0	42.0	M5*0.8P
DN25	1"	25.0	125.0	166.0	102.0	12.0	52.0	11.0	14.3	115.0	85.0	68.0	18.0	2.0	4	14.0	50.0	M6*1.0P
DN32	1-1/4"	32.0	130.0	166.0	105.0	12.0	56.0	11.0	14.3	140.0	100.0	78.0	18.0	2.0	4	18.0	50.0	M6*1.0P
DN40	1-1/2"	38.0	140.0	198.0	125.0	12.0	65.3	14.0	18.0	150.0	110.0	88.0	18.0	2.0	4	18.0	70.0	M8*1.25P
DN50	2"	50.0	150.0	198.0	132.0	12.0	73.8	14.0	18.0	165.0	125.0	102.0	20.0	2.0	4	18.0	70.0	M8*1.25P