

### Threaded 90° Branch Outlet

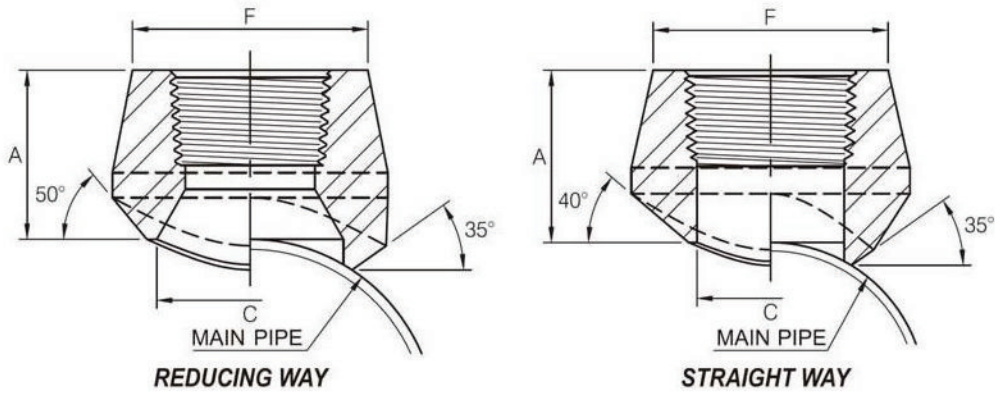

OutLet Pipe NPS	Reducing Way					
	A		C		F	
	3000Lb	6000Lb	3000Lb	6000Lb	3000Lb	6000Lb
1/8"	19.0	-	13.7	-	17.3	-
1/4"	19.0	-	13.7	-	22.0	-
3/8"	20.6	-	17.1	-	25.9	-
1/2"	25.4	31.8	21.3	16.6	31.4	33.9
3/4"	26.9	36.6	26.7	21.2	37.1	41.2
1"	33.3	39.6	33.4	27.0	45.5	49.9
1-1/4"	33.3	41.1	42.2	35.8	57.0	58.6
1-1/2"	35.0	42.3	48.3	41.2	64.0	66.7
2"	38.1	52.3	60.3	51.6	76.0	83.2
2-1/2"	46.0	-	73.0	-	92.0	-
3"	50.8	-	88.9	-	109.2	-
4"	57.2	-	114.3	-	140.0	-

OutLet Pipe NPS	Straight Way		
	A	C	F
	3000Lb		
1/8"	-	-	-
1/4"	19.0	11.5	22.0
3/8"	21.0	14.5	25.9
1/2"	25.4	16.5	31.4
3/4"	26.9	21.5	37.1
1"	33.3	27.2	45.5
1-1/4"	33.3	36.0	57.0
1-1/2"	35.0	42.0	64.0
2"	38.1	53.0	76.0
2-1/2"	46.0	65.0	92.0
3"	50.8	80.0	109.2
4"	57.2	104.0	140.0

- (1) 3000LBS outlet size 4 and less fit a number of run pipe sizes and the fittings are marked accordingly.
- (2) Dimensions in accordance with MSS SP-97-2012.

### Conventional Run Size Combinations

		OUTLET SIZE										
		1/4"	3/8"	1/2"	3/4"	1"	1-1/4"	1-1/2"	2"	2-1/2"	3"	4"
RUN SIZE (Main Pipe)	Reducing way	3/8"~3/4" 1"~36"	1/2" 3/4"~1-1/4" 1-1/2"~36"	3/4" 1" 1-1/4" 1-1/2"~3" 3-1/2"~36"	1" 1-1/4" 1-1/2" 2"~3" 3-1/2"~6" 8"~36"	1-1/4" 1-1/2" 2" 2-1/2" 3" 3-1/2"~4" 5"~10" 12~36"	1-1/2" 2" 2-1/2" 3" 3-1/2"~5" 6"~8" 10"~36"	2" 2-1/2" 3" 3-1/2" 4"~5" 6"~10" 12"~36"	2-1/2" 3" 3-1/2" 4" 5"~6" 8"~10" 12"~18" 20"~36"	3" 3-1/2" 4" 5" 6" 8" 10"~14" 16"~36"	3-1/2" 4" 5" 6" 8" 10" 12"~16" 18"~36"	5" 6" 8" 10" 12"~14" 16"~18" 20"~24" 26"~36"
	Straight way	3/8"~36"	1/2"~36"	3/4"~36"	1"~36"	1-1/4"~1-1/2" 2"~36"	1-1/2" 2"~3" 3-1/2"~36"	2" 2-1/2"~4" 5"~36"	2-1/2" 3"~3-1/2" 4"~6" 8"~36"	3" 3-1/2"~4" 5"~8" 10"~36"	3-1/2" 4" 5" 6" 8"~12" 14"~36"	5" 6" 8" 10" 12"~16" 18"~36"

Each charted outlet size is designed to fit a number of run pipe size.