

2 Piece Ball Valve Flanged 150#, Full Port

Features

1. Face to face: ANSI B16.10
2. End Flange: ANSI B16.5
3. Design: ANSI B16.34
4. Investment casting
5. Blow-out proof stem
6. Pressure: 150#

Options

1. Carbon/ Stainless steel body construction
2. Locking device available if requested

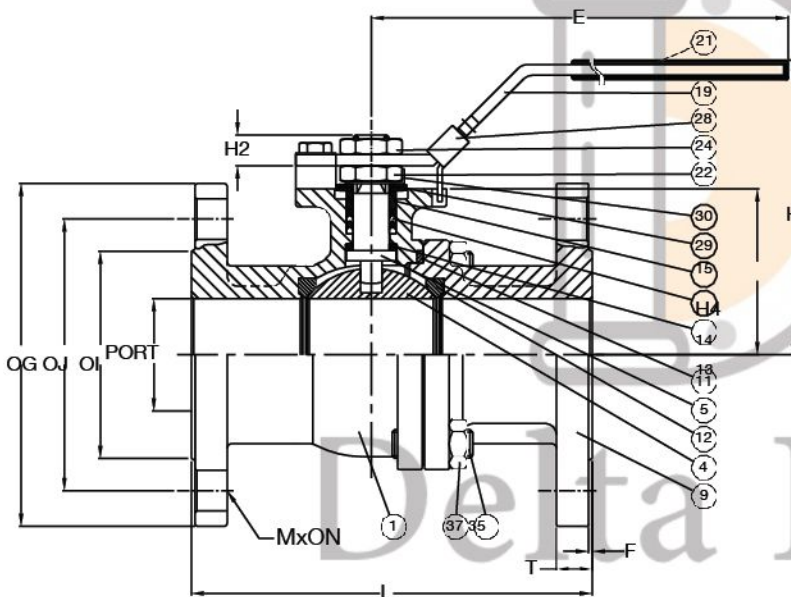
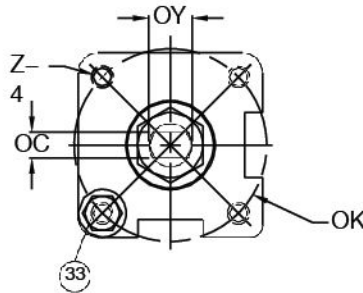

Materials List

NO.	PART NAME	MATERIAL	
1	BODY	ASTM A351 Cr.CF8M	ASTM A216 Gr.WCB
4	BALL	ASTM A351 Cr.CF8M	ASTM A351 Cr.CF8
5	STEM	SS316	SS304
9	END CAP	ASTM A351 Cr.CF8M	ASTM A216 Gr.WCB
11	BODY SEAL	PTFE.	
12	SEAT	RTFE.	
13	THRUST WASHER	PTFE.	
14	STEM PACKING	PTFE.	
15	GLAND BUSH	SS304	
19	HANDLE	SS304	
21	HANDLE COVER	PLASTIC	
22	STEM NUT	SS304	
24	HANDLE NUT	SS304	
28	LOCKING PAD	SS304	
29	BELLEVILLE WASHER	SS301	
30	TAB WASHER	SS304	
33	STOP PIN	SS304	
35	BODY BOLT	ASTM A193 Gr.B8	ASTM A193 Gr.B7
37	BOLT NUT	ASTM A193 Gr.8	ASTM A193 Gr.2HM

Dimensions

Size	PORT	L	E	H	H2	H4	C	ØY	ØG	ØJ	ØI	T	F	M	ØN	ØK	Z	
1/2"	DN15	15.0	108.0	132.0	80.0	8.5	38.5	6.4	9.6	89.0	60.5	35.0	11.2	1.6	4	16.0	42.0	M5*0.8P
3/4"	DN20	20.0	117.0	132.0	84.5	8.5	42.5	6.4	9.6	98.6	70.0	43.0	12.7	1.6	4	16.0	42.0	M5*0.8P
1"	DN25	25.0	127.0	166.0	102.0	12.0	52.0	8.0	11.2	108.0	79.2	51.0	14.3	1.6	4	16.0	50.0	M6*1.0P
1-1/4"	DN32	32.0	140.0	166.0	105.0	12.0	56.0	8.0	11.2	117.5	88.9	63.5	15.9	1.6	4	16.0	50.0	M6*1.0P
1-1/2"	DN40	38.0	165.0	198.0	125.0	12.0	65.3	9.5	16.0	127.0	98.6	73.2	17.5	1.6	4	16.0	70.0	M8*1.25P
2"	DN50	50.0	178.0	198.0	132.0	12.0	73.8	9.5	16.0	152.5	120.7	92.0	19.1	1.6	4	19.0	70.0	M8*1.25P