

3-Way Ball Valve 1000WOG, STD Port, L-Port/ T-Port



Features

1. Thread ends: NPT, BSPP, BSPF, BSPT, PT
2. Investment casting
3. Blow-out proof stem
4. Pressure: 1000WOG

Options

1. Carbon/ Stainless steel body construction
2. Locking device is available if requested

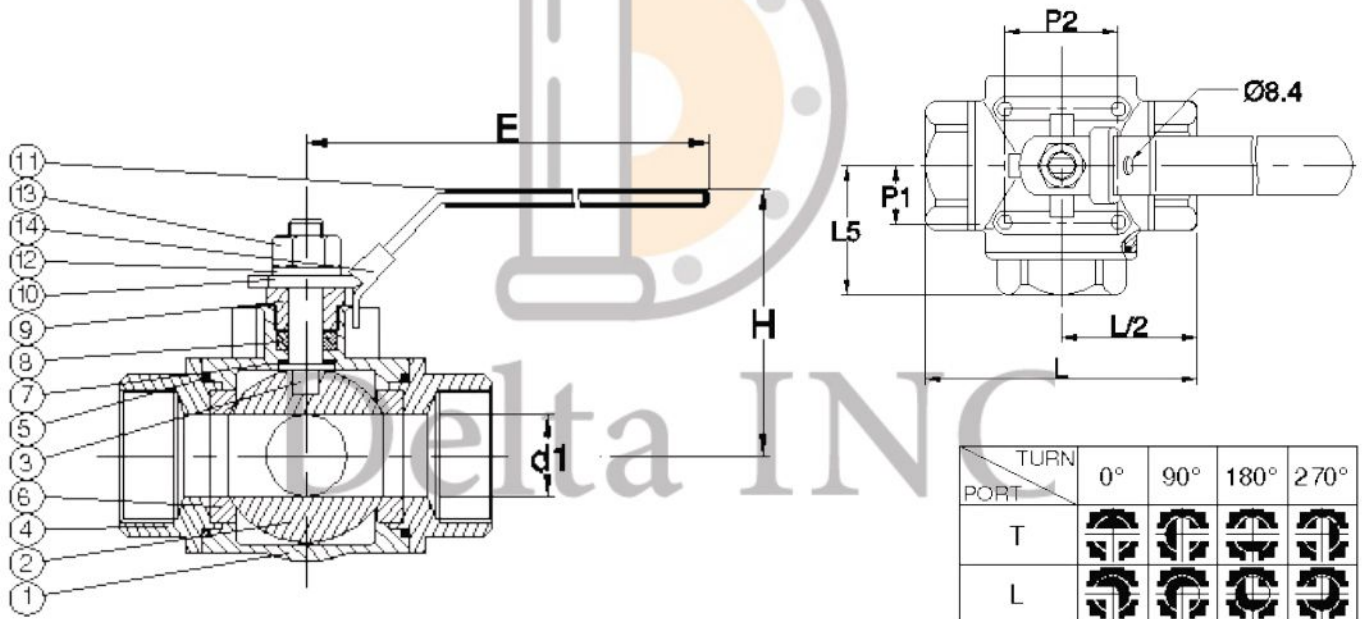

Dimension

SIZE		d1	L	L5	E	H	M	P1	P2
DN8	1/4"	11.0	69.4	35.0	106.0	61.0	10-24 UNC	13.0	28.5
DN10	3/8"	11.0	69.4	35.0	106.0	61.0	10-24 UNC	13.0	28.5
DN15	1/2"	12.7	76.0	37.5	138.0	65.5	10-24 UNC	13.0	28.5
DN20	3/4"	16.0	86.6	45.0	138.0	71.0	10-24 UNC	21.0	34.6
DN25	1"	20.0	102.0	51.0	157.0	76.0	10-24 UNC	21.0	34.6
DN32	1-1/4"	25.0	118.0	58.0	157.0	81.5	10-24 UNC	24.0	38.0
DN40	1-1/2"	32.0	126.0	63.0	220.0	102.0	1/4"-20 UNC	24.0	38.0
DN50	2"	38.1	149.0	77.0	220.0	112.2	1/4"-20 UNC	24.0	38.0

Material List

NO.	PART NAME	MATERIAL
1	BODY	SS316
2	BALL	SS316
3	STEM	SS316
4	END CAP	SS316
5	BODY SEAL	PTFE.
6	SEAT	PTFE.
7	THRUST WASHER	PTFE.
8	STEM PACKING	PTFE.
9	GLAND NUT	SS304
10	HANDLE	SS304
11	HANDLE COVER	PALSTIC
12	HANDLE WASHER	SS304
13	HANDLE NUT	SS304
14	LOCKING PAD	SS304