

Cap Threaded

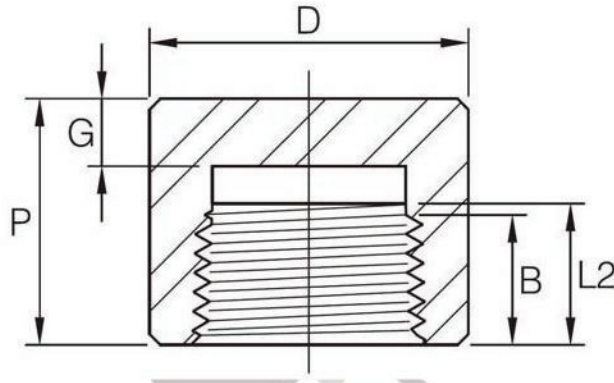

DN	Nom. Pipe Size	End to End P		Outside Diameter D		End Wall Thickness G (Min)		Length of Thread (Min)	
		3000Lb	6000Lb	3000Lb	6000Lb	3000Lb	6000Lb	B ⁽¹⁾	L2 ⁽¹⁾
6	1/8"	19	-	16	-	4.8	-	6.4	6.7
8	1/4"	25	27	19	25	4.8	6.4	8.1	10.2
10	3/8"	25	27	22	32	4.8	6.4	9.1	10.4
15	1/2"	32	33	28	38	6.4	7.9	10.9	13.6
20	3/4"	37	38	35	44	6.4	7.9	12.7	13.9
25	1"	41	43	44	57	9.7	11.2	14.7	17.3
32	1-1/4"	44	46	57	64	9.7	11.2	17.0	18.0
40	1-1/2"	44	48	64	76	11.2	12.7	17.8	18.4
50	2"	48	51	76	92	12.7	15.7	19.0	19.2
65	2-1/2"	60	64	92	108	15.7	19.0	23.6	28.9
80	3"	65	68	108	127	19.0	22.4	25.9	30.5
100	4"	68	75	140	159	22.4	28.4	27.7	33.0

- (1) Dimension B is minimum length of perfect thread. The length of useful thread (B plus threads with fully formed roots and flat crests) shall not be less than L2 (effective length of external thread) required by American National Standard for pipe threads (ANSI / ASME B1.20.1).
- (2) Dimensions in accordance with ASME B16.11-2011.