

Stub End

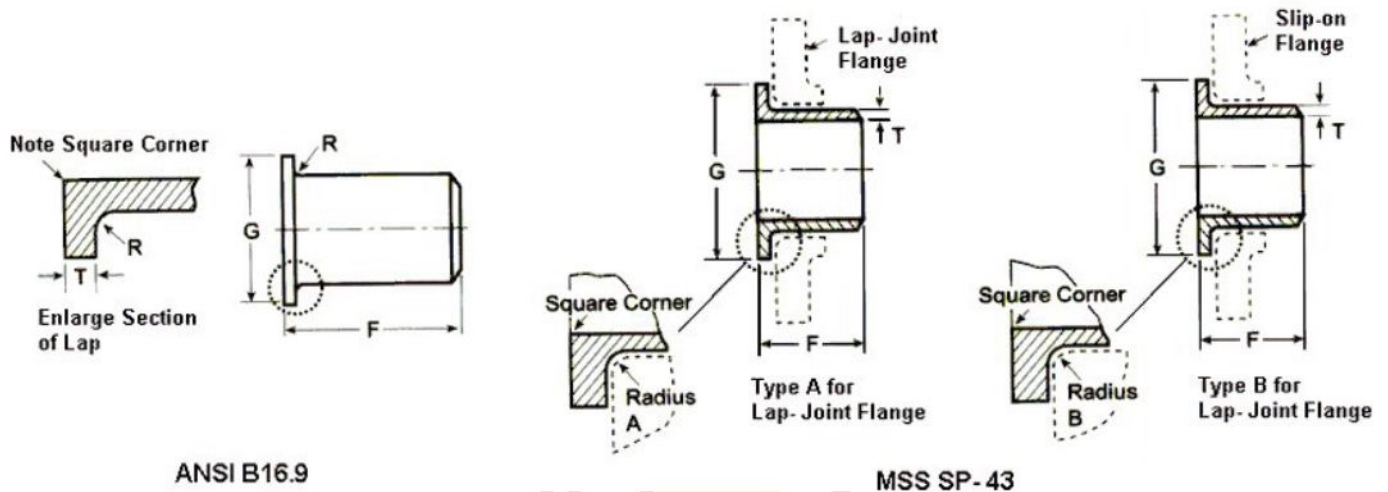

ANSI B16.9

MSS SP-43

ANSI B16.9 / MSS SP-43 (in mm)

Nominal Pipe Size (NPS)	Outside Diameter at Bevel	Outside Diameter of Barrel		Length F		Radius of Fillet R		Diameter of Lap G
		Min.	Max.	ANSI	MSS	ANSI & MSS Type A	MSS Type B	
1/2	21.3	20.55	22.76	76.2	50.8	3.0	0.8	35.0
3/4	26.7	25.88	28.09	76.2	50.8	3.0	0.8	42.9
1	33.4	32.61	34.95	101.6	50.8	3.0	0.8	50.8
1-1/4	42.2	41.38	43.59	101.6	50.8	4.8	0.8	63.5
1-1/2	48.3	47.47	49.94	101.6	50.8	6.4	0.8	73.2
2	60.3	59.54	62.38	152.4	63.5	7.9	0.8	91.9
2-1/2	73.0	72.24	75.34	152.4	63.5	7.9	0.8	104.6
3	88.9	88.11	91.34	152.4	63.5	9.7	0.8	127.0
3-1/2	101.6	100.81	104.04	152.4	76.2	9.7	0.8	139.7
4	114.3	113.51	116.66	152.4	76.2	11.2	0.8	157.2
5	141.3	140.51	144.35	203.2	76.2	11.2	1.5	185.7
6	168.3	167.49	171.27	203.2	88.9	12.7	1.5	215.9
8	219.1	218.29	222.07	203.2	101.6	12.7	1.5	269.7
10	273.1	272.26	277.19	254.0	127.0	12.7	1.5	323.9
12	323.9	323.06	327.99	254.0	152.4	12.7	1.5	381.0
14	355.6	354.81	359.92	304.8	152.4	12.7	1.5	412.8
16	406.4	405.61	410.97	304.8	152.4	12.7	1.5	469.9
18	457.2	456.41	462.03	304.8	152.4	12.7	1.5	533.4
20	508.0	507.21	514.10	304.8	152.4	12.7	1.5	584.2
22	558.8	558.01	564.90	304.8	152.4	12.7	1.5	641.4
24	609.6	608.81	615.70	304.8	152.4	12.7	1.5	692.2